

Product information

Drummotors

TM 400-60



Van der Graaf
Power Transmission Equipment

www.vandergraafpte.nl

The TM 400's playground

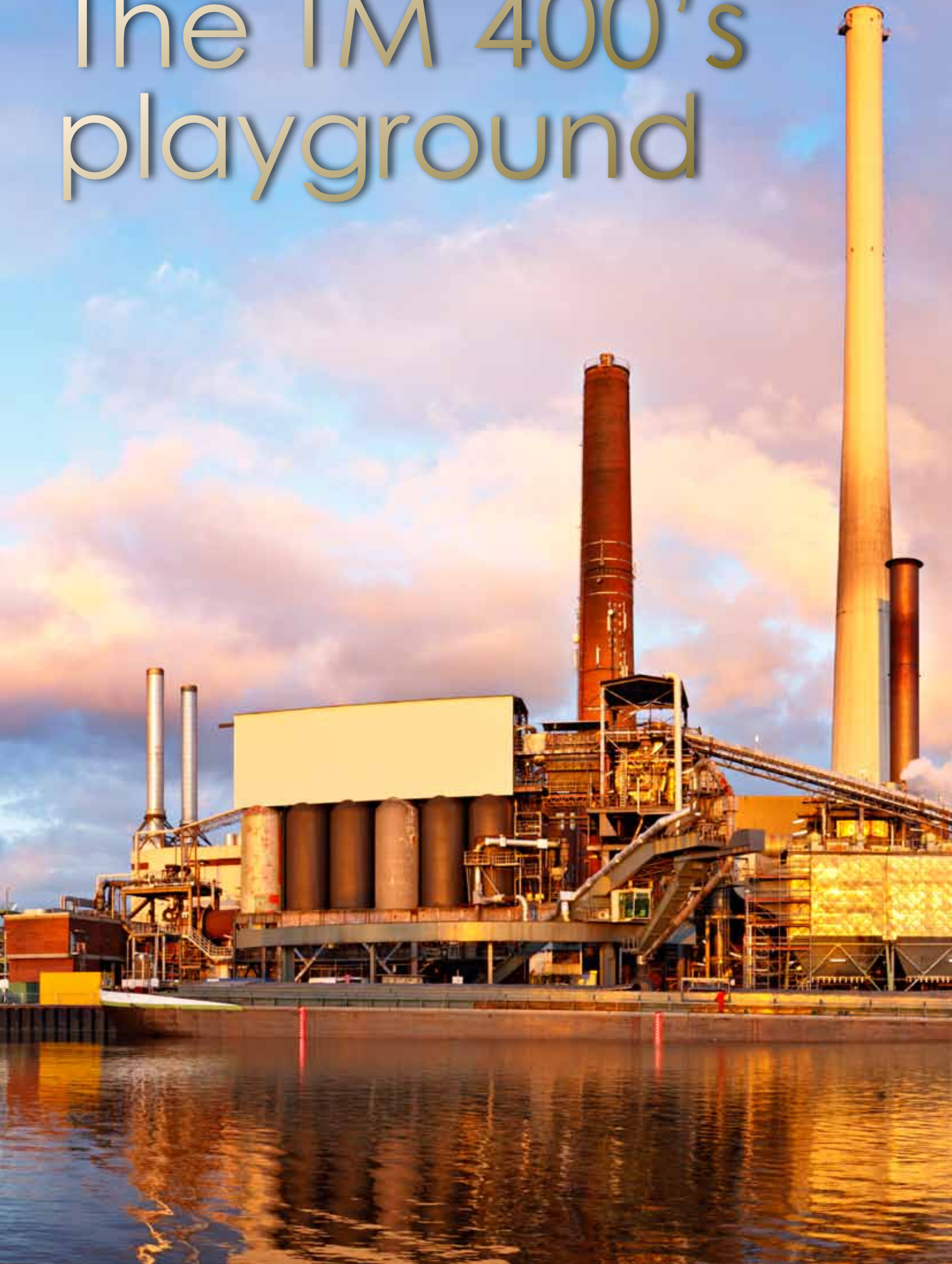



TM 400-60



A wide range of applications

Van der Graaf has achieved a prominent position on both the domestic and international market with its "GV" Drummotors.

The "GV" Drummotor has found success in a wide range of applications including the following: automotive, X-ray, construction, postal, courier, mining, aggregate, airline baggage, package flow, tyre manufacturing, fish processing, poultry processing, meat processing, agriculture, fruit and vegetable, farming, forestry, baking, dairy and many more.

4	Introduction
5	Selection table
6	Selection table Dahlander motors
7	Dimensions Drummotors
8	Dimensions Taildrums
9	Dimensions bracket
10	Cable exit
12	Cross sectional / parts description
14	Options
17	Product range
18	Notes
20	Contact us



Selection table

TYPE	Power kW	Beltspeed m/s at 50 Hz						Min. L mm	Min. L mm	Full load curr. 400 V - 50 Hz I = ... A	Weight kg	
TM 400.60		Beltpull N						Design A	Design B		L=650	
230 230 Z 230 ZV	22,0	4,20 4975 3,60 5805 3,00 6965	2,60 8040	2,20 9500				700	750	39,0	283	
225 225 Z 225 ZV	18,5	4,20 4180 3,60 4880 2,60 6760	3,00 5885	2,20 7985				700	750	32,5	283	
220 220 ZV	15,0	4,60 3100 2,20 6475	3,40 4190 1,80 7915	2,60 5480 1,60 8905	1,30 10960			650	700	26,0	273	
415 415 Z 415 ZV	11,0	4,10 2550 1,80 5805 1,50 6965	3,70 2825	2,70 3870	2,10 4975			650	700	21,0	273	
410 410 ZV	7,5	4,10 1740 1,10 6475	3,70 1925 0,90 7915	2,70 2640 0,80 8905	2,30 3100 0,65 10960	1,70 4190	1,30 5480	600	650	14,5	258	
475 475 Z 475 ZV	5,5	3,70 1410 0,90 5805 0,80 6530	2,70 1935	2,50 2090	2,30 2270	1,70 3075	1,30 4020	1,00 5225	600	650	12,0	253
455 455 Z	4,0	3,70 1025 0,90 4220	2,70 1405 0,80 4750	2,50 1520 0,65 5845	2,30 1650	1,70 2235	1,30 2925	1,00 3800	600	650	9,5	248
655 655 ZV	4,0	1,50 2535 0,60 6335	0,50 7600	0,45 8445				600	650	9,2	253	
640 640 Z	3,0	1,70 1675 0,60 4750	1,50 1900 0,50 5700	1,10 2590 0,45 6335	0,85 3355	0,65 4385		600	650	7,0	248	
840 840 ZV	3,0	1,25 2280 0,40 7125	0,32 8905					600	650	8,7	253	
830 830 Z	2,2	1,25 1670 0,45 4645	1,10 1900 0,40 5225	0,80 2615 0,32 6530	0,65 3215	0,50 4180		600	650	8,0	248	
1230 1230 ZV	2,2	0,75 2785 0,28 7465	0,55 3800 0,25 8360	0,20 10450				600	650	8,2	258	
1220 1220 Z 1220 ZV	1,5	0,80 1780 0,28 5090 0,20 7125	0,75 1900 0,25 5700	0,55 2590	0,40 3565	0,30 4750		600	650	5,1	253	

Available standard facewidth's: 600 - 650 - 700 - 750 - 800 - 850 - 900 - 950 - 1000 - 1050 - 1100 - 1150 mm

When an electro-mechanical brake is fitted, the minimum facewidth is increased by 150 mm

When a backstop is fitted in a 2-pole Drummotor, the minimum facewidth is increased by 50 mm

The total weight of a Drummotor grows approx. 12 kg per 100 mm

Available torque: (Beltpull N x drum diameter m) / 2 Nm

Selection table Dahlander motors

TYPE TM 400.60	Power kW	Beltspeed m/s at 50 Hz			Min. L mm Design A	Min. L mm Design B	Full load curr. 400 V - 50 Hz I = ... A	Weight kg L=650
		Beltpull N						
410/220	7,5/15,0	2,10/4,20 3395			650	700	14,2/28,5	273
410/220 Z		1,80/3,60 3960	1,50/3,00 4750	1,30/2,60 5480				
410/220 ZV		1,10/2,20 6475						

Available standard facewidth's: 650 - 700 - 750 - 800 - 850 - 900 - 950 - 1000 - 1050 - 1100 - 1150 mm

For facewidth's above 1000 mm contact the engineering department for calculation of reinforced shaft

When an electro-mechanical brake is fitted, the minimum facewidth is increased by 150 mm

When a backstop is fitted in a 2-pole Drummotor, the minimum facewidth is increased by 50 mm

The total weight of a Drummotor grows approx. 12 kg. per 100 mm

Available torque: (Beltpull N x drum diameter m) / 2 Nm



Dimensions Drummotors

TM 400A60

TM 400A60, mild steel Drummotor with cast iron junctionbox

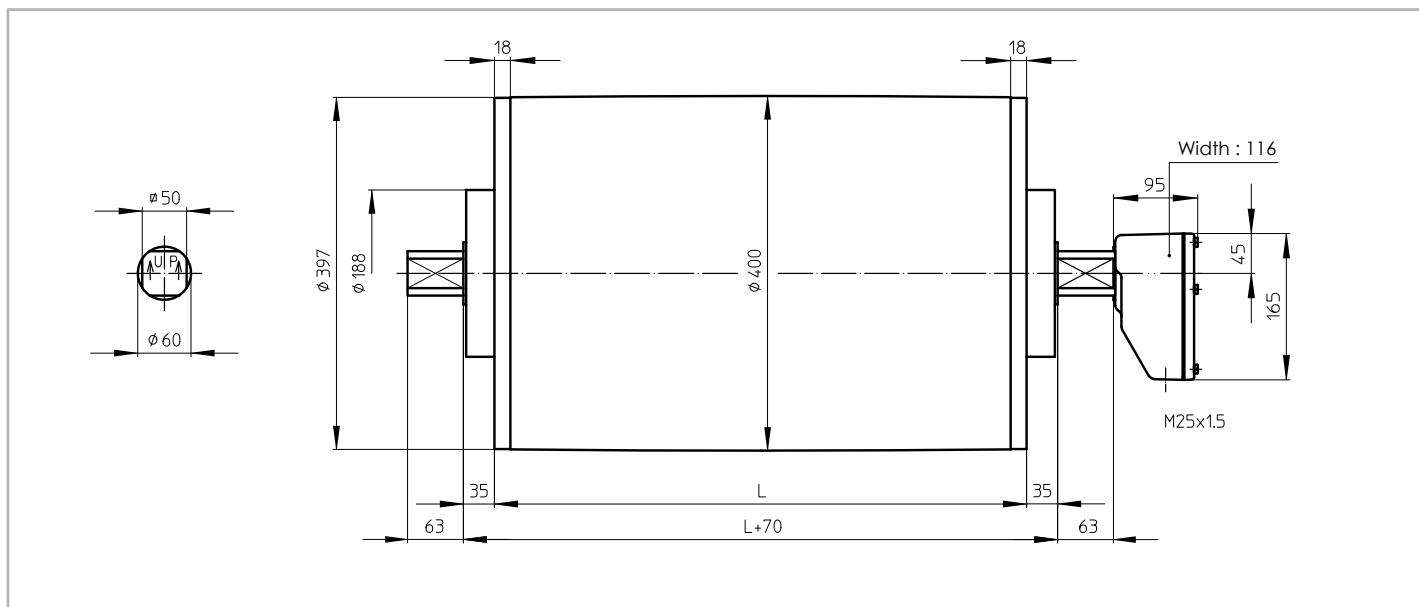

TM 400B60

TM 400B60, mild steel Drummotor with cast iron junctionbox

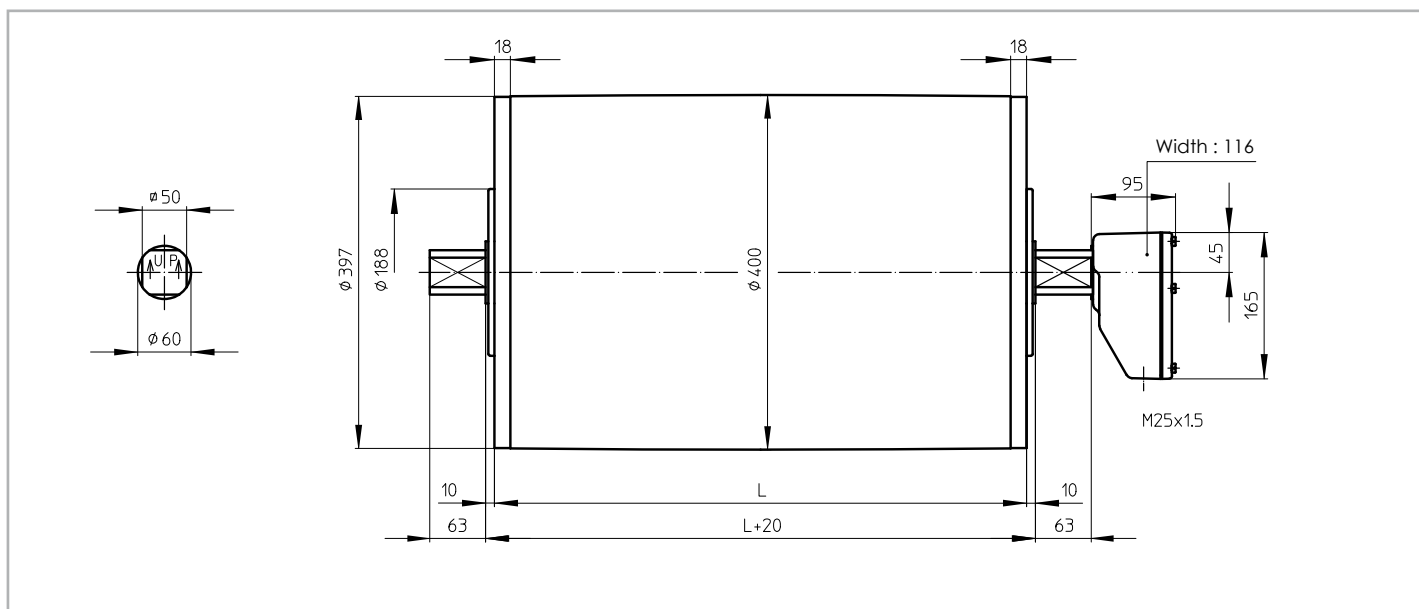

Dimensions Taildrums

KT 400A60

KT 400A60, mild steel Taildrum

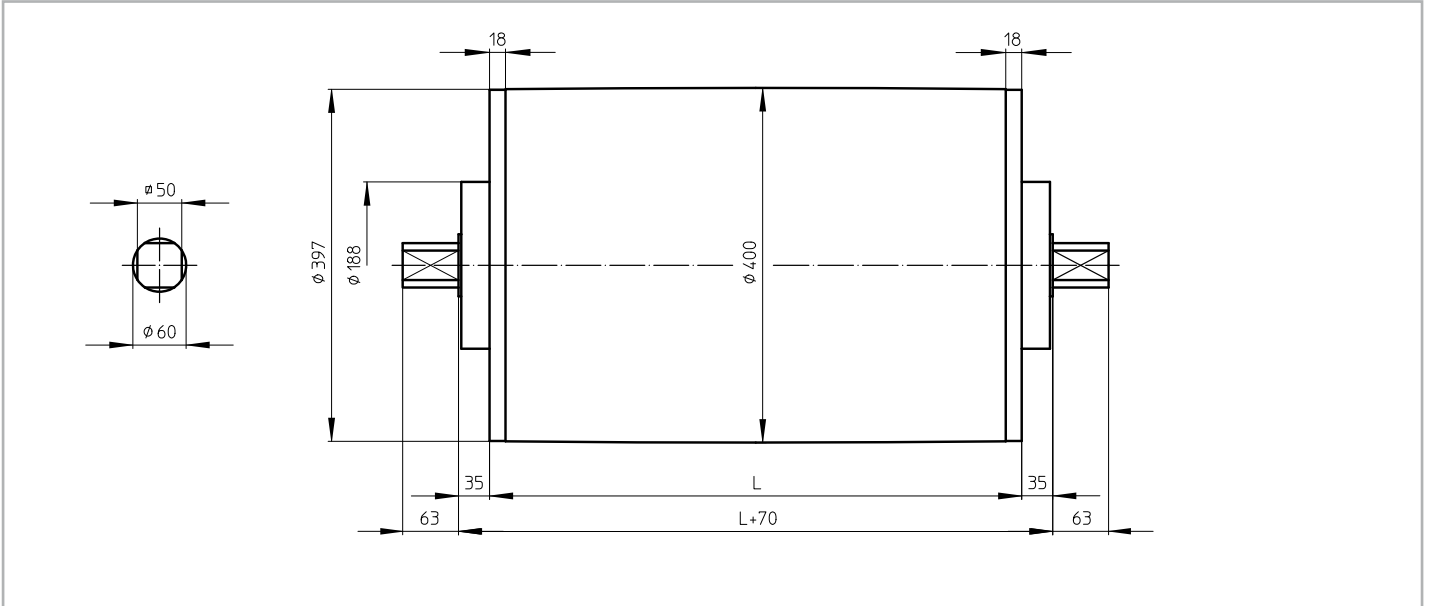

KT 400B60

KT 400B60, mild steel Taildrum

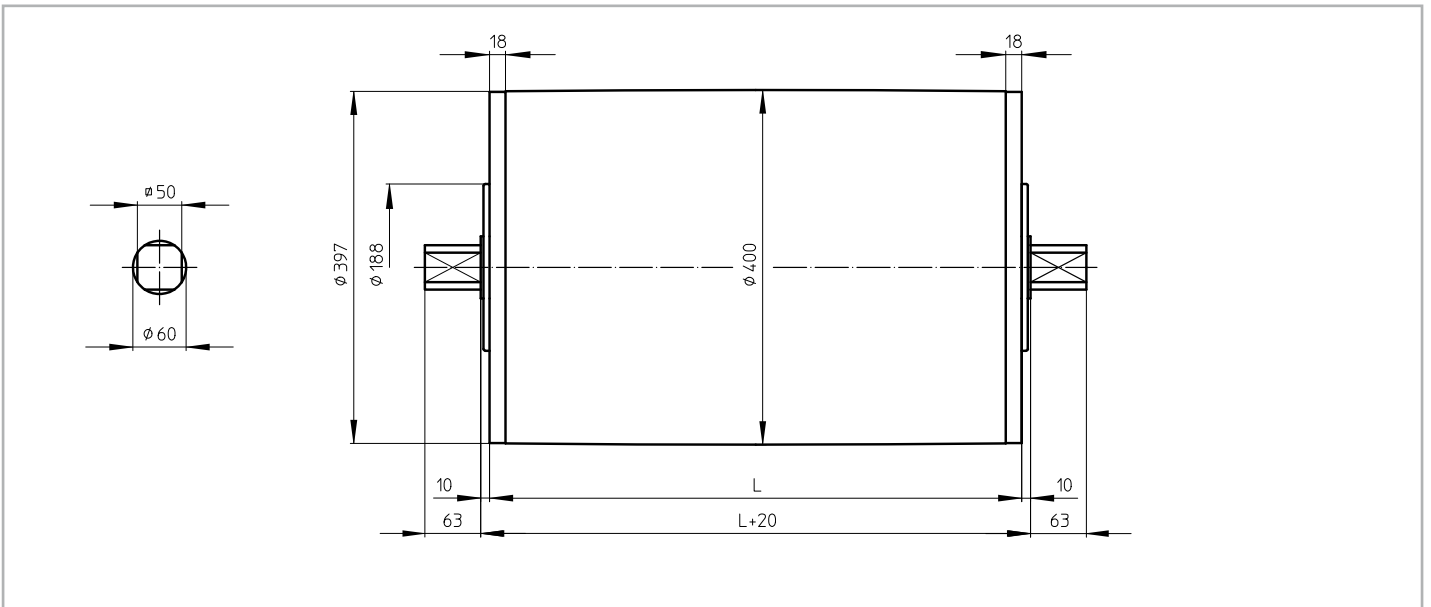



Dimensions bracket

AB 60

AB 60, cast iron or stainless steel bracket
Weight: 11,5 kg per pair

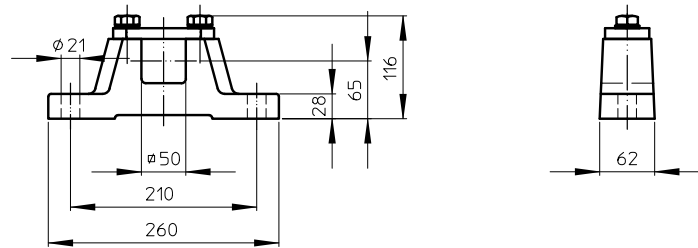

Cable exit

Standard execution of a TM 400-60 is with a cast iron junctionbox. For stainless steel execution, this can be either a PU coated cast iron or stainless steel junctionbox.

On request a Drummotor can be fitted with a cable. In this case it is important to know the available voltage (preferably 1 voltage), the length of the cable, whether the cable is shielded or not and the type of cable exit.

The available cable exit is shown below.

Option 1

Straight cable exit with cable gland

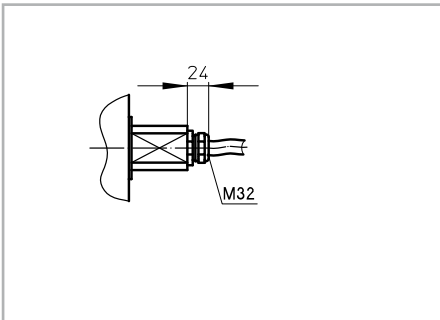



TM 400A60

Legenda

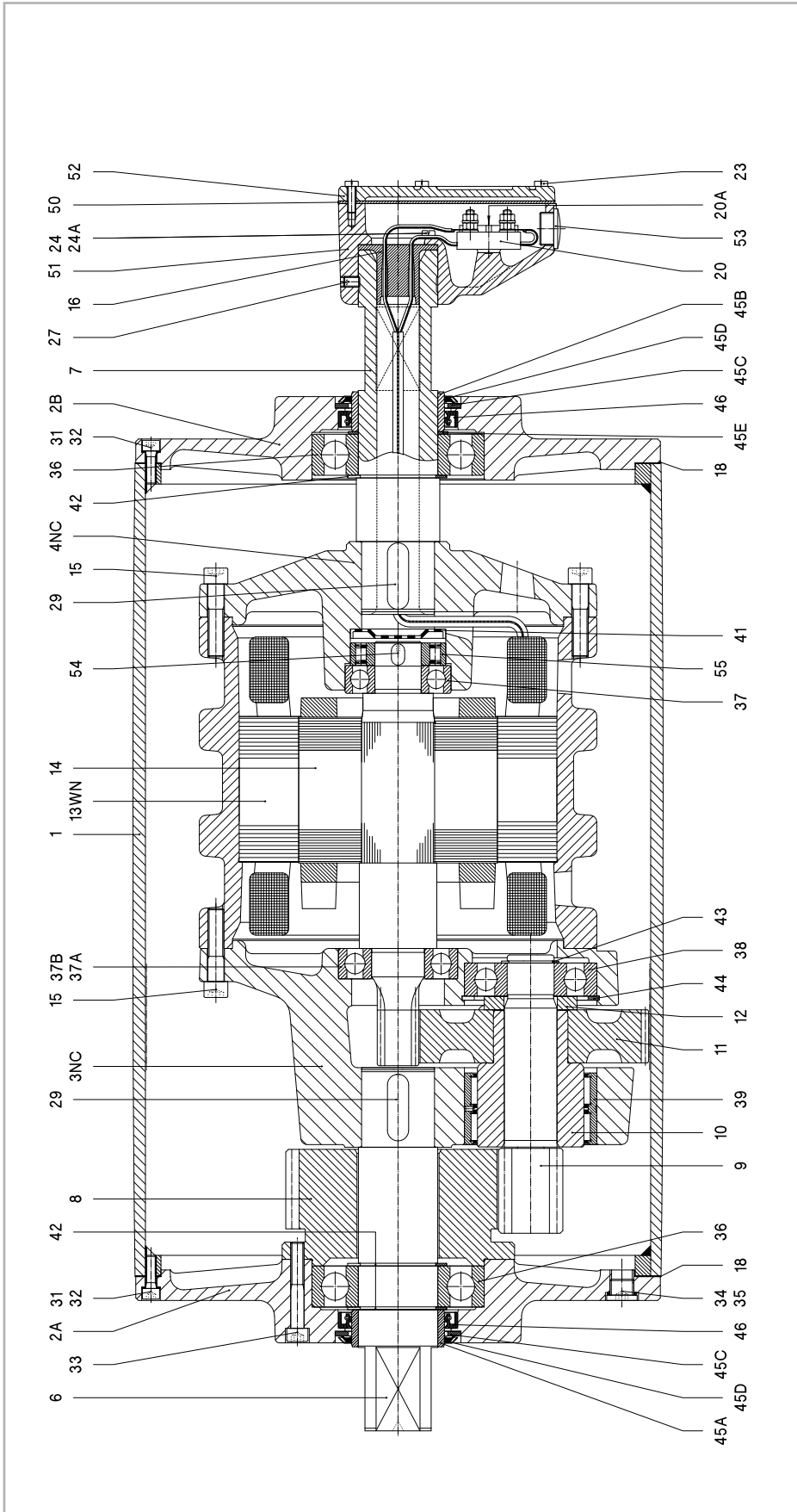

Remark: Drummotor also available in B-design (TM400B60)

1	Shell	13WN	Stator	29	Key	39	Needlebearing	50	Seal
2A	Endflange	14	Rotor	31	Int. hex screw	41	Disc	51	Junctionbox
2B	Endflange	15	Int. hex screw	32	Washer	42	Circlip	52	Junctionbox cover
3NC	Gearhousing	16	Cable passage	33	Int. hex screw	43	Circlip	53	Stopping plug
4NC	Motoflange	18	Gasket	34	Fillerplug	44	Circlip	54	Key
6	Shaftend	20	Terminalboard	35	Washer	45A	Bearing race	55	Backstop
7	Hollow shaft	20A	Cyl. head screw	36	Ballbearing	45B	Bearing race	57	Dataplate
8	External gear	23	Cyl. head screw	37	Ballbearing	45C	Shim plated		
9/10	Pinion with bush	24	Cyl. head screw	37A	Ballbearing	45D	Gammaring		
11	Gear	24A	Toothed lock washer	37B	Spherical bearing	45E	Shim		
12	Distance ring	27	Setscrew	38	Ballbearing	46	Oilseal		
		8							
		42							
		2A							
		31							
		32							
		36							
		42							
		15							
		37B							
		37A							
		29							
		3NC							
		1							
		13WN							
		14							
		1							
		54							
		29							
		15							
		4NC							
		42							
		36							
		31							
		2B							
		7							
		27							
		16							
		51							
		24							
		24A							
		50							
		52							
		20A							
		23							
		20							
		20							
		53							
		45B							
		45D							
		46							
		45C							
		18							
		45E							
		46							
		55							
		37							
		41							
		43							
		44							
		45A							
		45B							
		45C							
		45D							
		45E							
		46							
		39							
		41							
		42							
		43							
		44							
		45A							
		45B							
		45C							
		45D							
		45E							
		46							

Cross sectional / parts description

TM 400A60 Z

Legenda

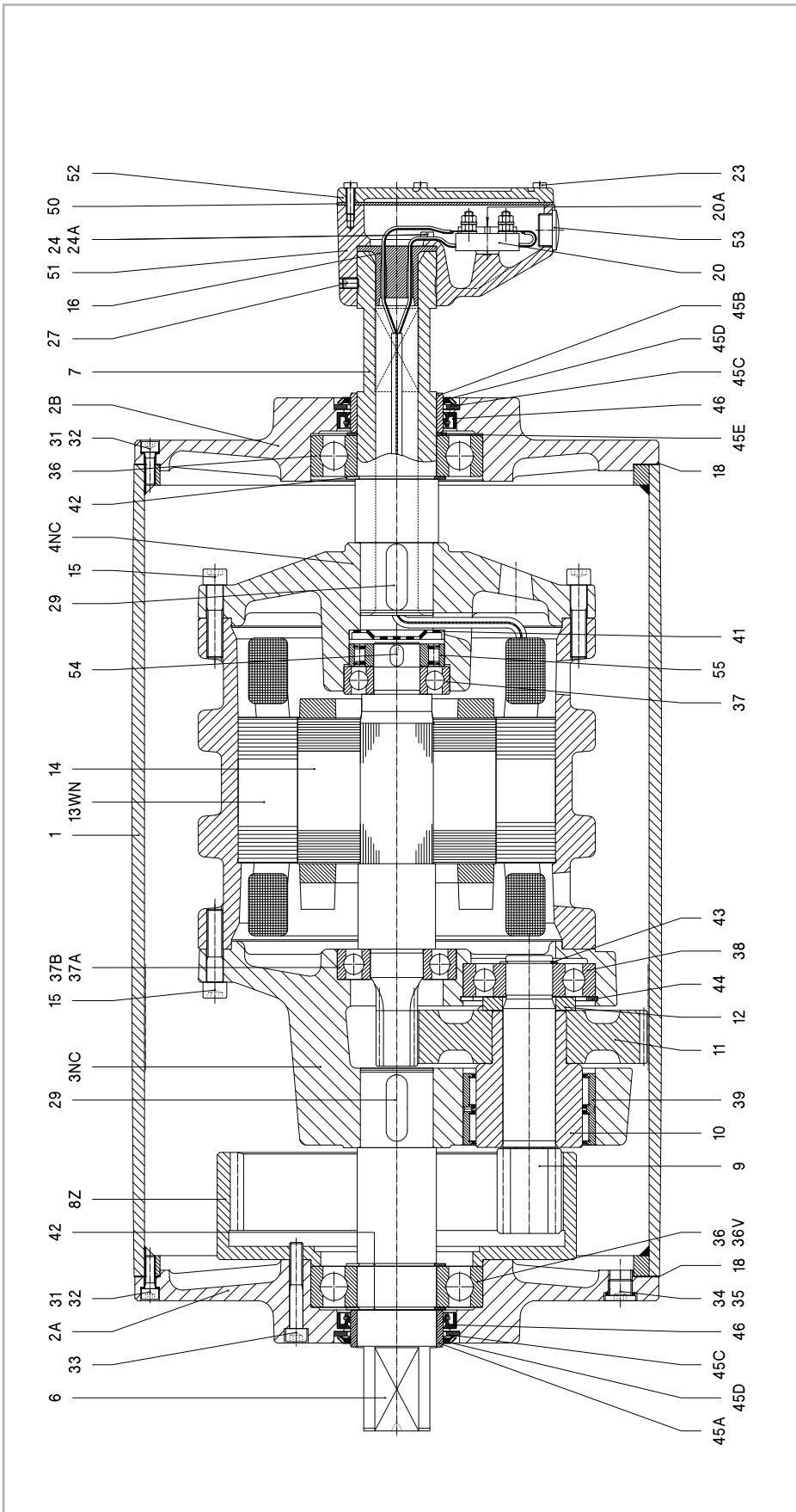

Remark: Drum motor also available in B-design (TM400B60 Z)

1	Shell	13WN	Stator	29	Key	38	Ballbearing	46	Oilseal
2A	Endflange	14	Rotor	31	Int. hex screw	39	Needlebearing	50	Seal
2B	Endflange	15	Int. hex screw	32	Washer	41	Disc	51	Junctionbox
3NC	Gearhousing	16	Cable passage	33	Int. hex screw	42	Circlip	52	Junctionbox cover
4NC	Motarfange	18	Gasket	34	Fillerplug	43	Circlip	53	Stopping plug
6	Shaftend	20	Terminalboard	35	Washer	44	Circlip	54	Key
7	Hollow shaft	20A	Cyl. head screw	36	Ballbearing	45A	Bearing race	55	Backstop
8Z	Internal gear	23	Cyl. head screw	36V	Cyl. roller bearing	45B	Bearing race	57	Dataplate
9/10	Pinion with bush	24	Cyl. head screw	37	Ballbearing	45C	Shim plated		
11	Gear	24A	Toothed lock washer	37A	Ballbearing	45D	Gammaring		
12	Distance ring	27	Setscrew	37B	Spherical bearing	45E	Shim		

KT 400A60

Legenda

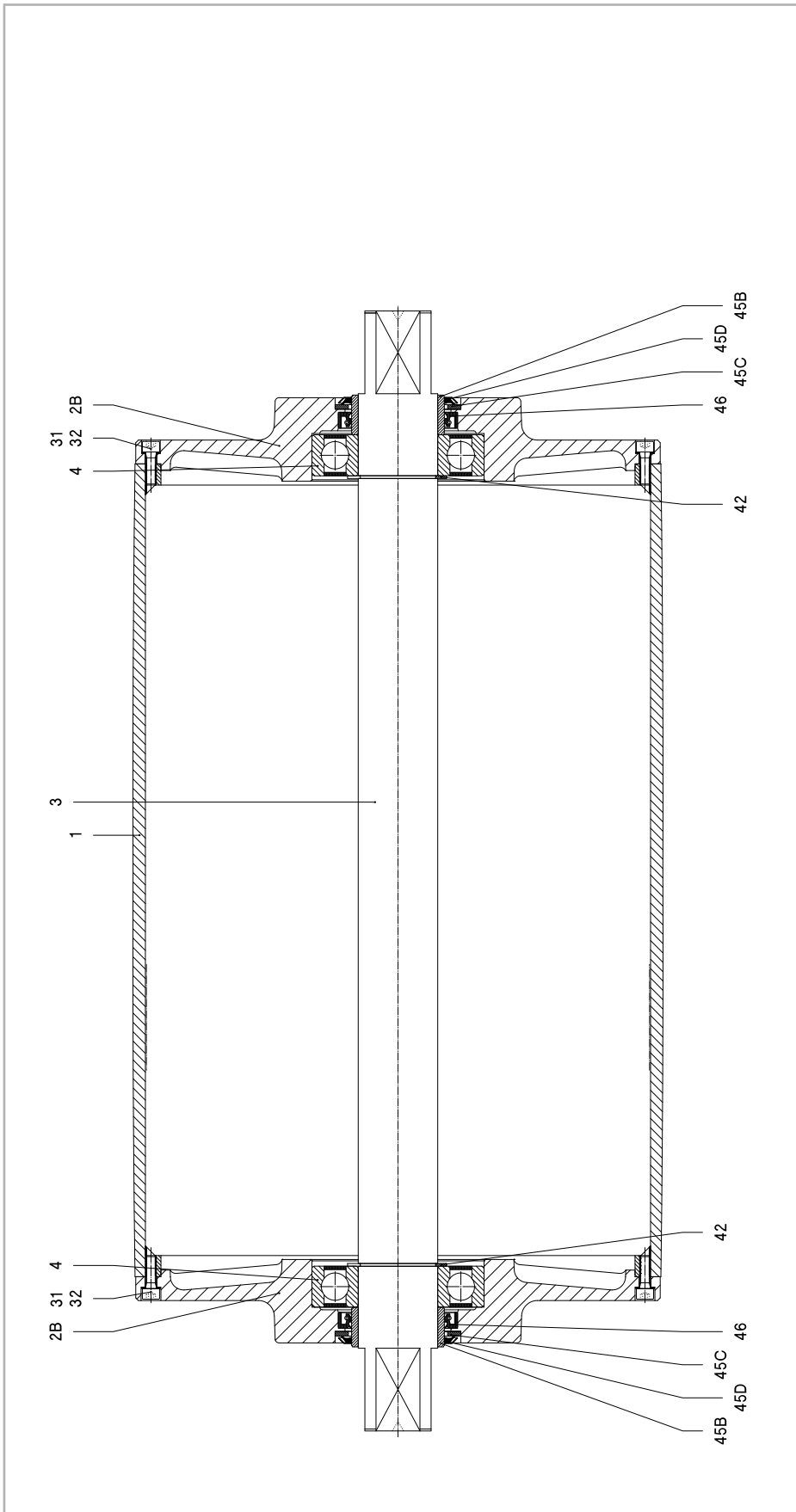

Remark: Taildrum also available in B-design (KT400B60)

1	Shell	42	Circlip
2B	Endflange	45B	Bearing race
3	Shaft	45C	Shim plated
4	Ballbearing	45D	Gammaring
31	Int. hex screw	46	Oliseal
32	Washer		

Material

The external parts of the Drummotor are made from mild steel and cast iron. Depending on the application it is also possible to manufacture in stainless steel (complete or part). You can choose between stainless steel 304 (general food industry) and stainless steel 316 (salt water applications).

Backstop - Brake

If an inclined belt conveyor is stopped fully loaded, it could run backwards.

To prevent this we can install a backstop. One of the bearings in the Drummotor is replaced by a one way bearing. The way this bearing is installed determines the direction of rotation of the drum. TBRH indicates a cw rotation and TBLH ccw.

In situations where a Drummotor needs to be able to drive in both directions it is not possible to use a backstop. In this case we use a brake. When an declined belt or a horizontal belt needs to be stopped quickly to pick or place items a brake is the best solution.

Inclined position

Sometimes a Drummotor needs to be installed on an inclined or even vertical position. This is possible, but we need to make adjustments to the oil level in the drum as the oil will flow to the lower side of the Drummotor causing the top bearing to run without lubrication. To prevent problems we will need to know the installation angle so we can fill the drum with extra oil and fit a double sealed bearing on the upper side.

Thermal protection

A Van der Graaf Drummotor can be fitted with thermal protection. This consists of either a thermistor (PTC) or bi-metal (klixon). We install these on each phase of the electric motor.

Encoder - Sensor bearing

In certain applications it is required to measure the speed or position of a conveyor belt. For this type of application we can install an encoder or sensor bearing to accurately measure rotational speed of the Drummotor.

The accuracy needed will determine the type of encoder or sensor used.

Lagging

The power produced by the Drummotor has to be transferred to the belt and lagging is used to give more friction between the Drummotor and the conveyor belt. Van der Graaf can fit your Drummotor with different kinds of lagging.

There is a difference between cold and hot vulcanised lagging. Cold vulcanised means the lagging is glued to the Drummotor usually in sheet form and the join 'welded' together. Hot vulcanising is a process where the shell is wrapped around with thin layers of rubber. The shell with the rubber is then baked in an autoclave fusing the layers together creating a seamless finish.

It is possible to cut grooves (e.g chevron or diamond) in the lagging.

Sprockets

Do you wish to use a Drummotor to drive modular belts? Van der Graaf can help you! Fitting sprockets suitable for various types of modular belts is a simple solution. The Drummotor is manufactured with a cylindrical shell and machined with a patented 'keying' system. The sprockets are simply 'slid' on and locked securely into position.



Options

Sealings for mild steel Drummotors

RB sealing - IP 66



This is Van der Graaf's standard sealing. This type of sealing will work in most conditions.

RBS sealing - IP 66



This sealing is specifically designed for those applications where high water pressure is used for cleaning.

HD sealing - IP 66



This sealing is designed for abrasive applications, like sand, gravel and soil.

Sealing for stainless steel Drummotors

CR sealing - IP 66



This is our standard sealing for stainless steel Drummotors, a very effective, multi labyrinth sealing.

Options

Specification	Standard	Optional
Construction		
Shafts and bolts	Mild steel	Stainless steel
Endflanges	Cast iron	Stainless steel
Shell	Mild steel	Stainless steel
Junctionbox	Cast iron	PU coated cast iron or stainless steel
Cable		Shielded or non-shielded
Sealing mild steel	RB	RBS, HD
Sealing stainless steel	CR	
Shell		
Crowned	•	
Cylindrical		•
Balanced		•
Lagging, cold vulcanised		•
Lagging, hot vulcanised		•
Lagging, FDA approved		•
Fitted with grooves, patterns		•
Sprockets		•
Electro motor		
Three-phase asynchronous	•	
Power supply (P < 3 kW)	230/400 V - 50 Hz	Other voltages and frequencies on request
Power supply (P ≥ 3 kW)	400/690 V - 50 Hz	Other voltages and frequencies on request
Twin drive (double power)		•
Insulation class	F	H
Thermal protection		Bi-metal or thermistor
Run by frequency inverter	•	
Other options		
Food grade oil		•
Backstop, mechanical		•
Brake, electro mechanical		•
Clutch brake, electro mechanical		•
Inclined or vertical position		•
Other facewidth's		•
Different shaft designs		•
Encoder or sensor bearing in Drummotor		•
Encoder or sensor bearing in Taildrum		•
Certificates		
CE	•	
UL		•
CSA		•
ATEX zone 22, dust		•



Product range

Our products, an overview

Drum motor type	TM 100B25	TM 113B25	TM 127.25	TM 138.25	TM 160.25	TM 160.30	TM 215.30	TM 215.40
Drum diameter (mm)	100	113	127	138	160	160	215	215
Shaft diameter (mm)	25	25	25	25	25	30	30	40
Power (kW)	0.05-0.37	0.04-0.55	0.10-1.1	0.10-1.1	0.10-0.75	0.10-2.2	0.10-2.2	0.37-5.5
Speed (m/s)	0.007-3.60	0.008-4.40	0.008-2.60	0.009-2.80	0.13-3.30	0.06-4.00	0.08-5.30	0.12-4.70

Drum motor type	TM 215B50	TM 273.40	TM 315.40	TM 315.50	TM 400A50	TM 400.60	TM 500A60	TM 500A75
Drum diameter (mm)	215	273	315	315	400	400	500	500
Shaft diameter (mm)	50	40	40	50	50	60	60	75
Power (kW)	1.5-4.0	0.37-5.5	0.37-5.5	1.1-11	1.1-11	1.5-22	1.5-22	11-30
Speed (m/s)	0.18-0.31	0.17-5.00	0.18-5.20	0.16-4.40	0.20-4.80	0.20-4.60	0.25-4.70	0.80-3.20

Drum motor type	TM 620A75	TM 630A100	TM 800A100	TM 800A130				
Drum diameter (mm)	620	630	800	800				
Shaft diameter (mm)	75	100	100	130				
Power (kW)	11-30	22-55	22-55	55-132				
Speed (m/s)	1.00-3.90	1.00-4.00	1.25-5.10	1.60-4.50				

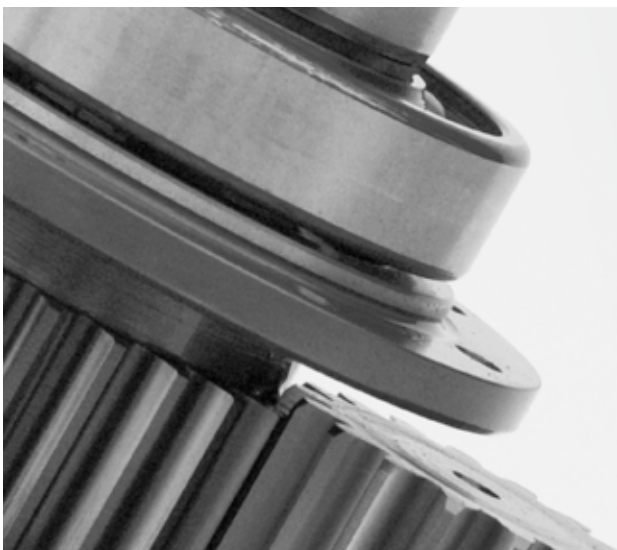

Design benefits

- Robust, industrial design
- Fully enclosed
- Oil filled
- Well-sized gears and bearings

Installation advantages

- Easy to install
- Compact and reliable
- Easy to clean
- Virtually maintenance free
- Low Life Cycle Costs



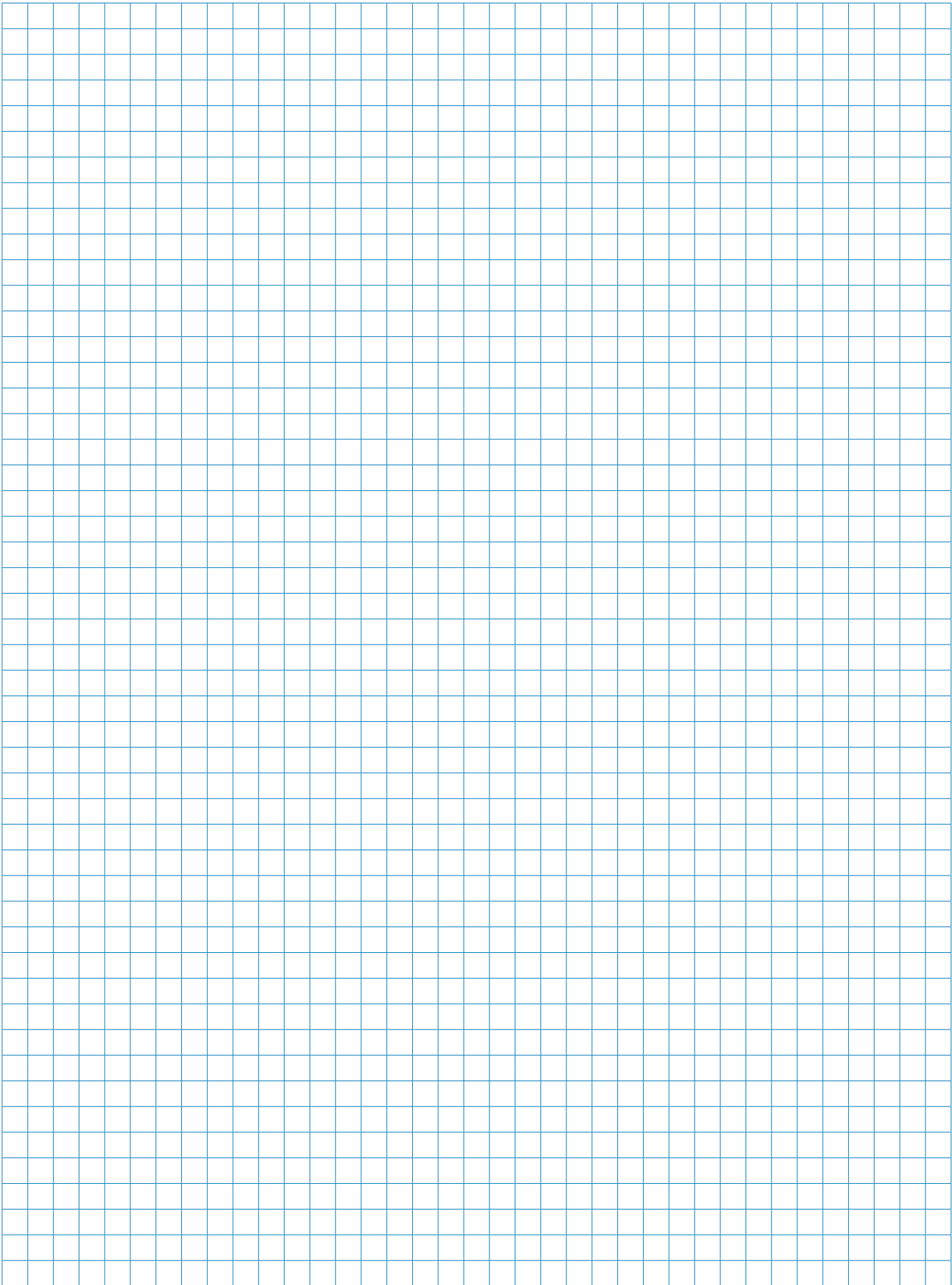



Van der Graaf

Power Transmission Equipment

Contact us

Netherlands

Van der Graaf B.V.
De Weijert 14
P.O. Box 3
8325 ZG Vollenhove
Tel: 00 31 527 241441
Fax: 00 31 527 241488
E-mail: info@vandergraafpte.nl
www.vandergraafpte.nl



Canada

Van der Graaf Inc.
2 Van der Graaf Court
Brampton
Ontario L6T 5R6
Tel: 00 1 905 793 8100
Fax: 00 1 905 793 812
E-mail: info@vandergraaf.com
www.vandergraaf.com



Great Britain

Van der Graaf U.K. Ltd.
Unit 23, The Metro Centre
Welbeck Way Woodston
Peterborough PE2 7UH
Tel: 00 44 1733 391777
Fax: 00 44 1733 391044
E-mail: sales@vandergraaf.co.uk
www.drummy.com



USA

Van der Graaf Corp.
51515 Celeste
Shelby Township
48315 Michigan
Tel: 00 1 866 595 3292
Fax: 00 1 888 326 0089



Germany

Van der Graaf GmbH
Rheiner Straße 24 B
48432 Rheine-Mesum
Tel: 00 49 5975 306210
Fax: 00 49 5975 3062120
E-mail: info@vandergraaf.de
www.vandergraaf.de



Sweden

Van der Graaf Scandinavia AB
Spinngatan 2
267 73 Billesholm
Tel: 00 46 42 22 0802
Fax: 00 46 42 22 0803
E-mail: info@vandergraaf.se
www.vandergraaf.se



Finland

Van der Graaf Scandinavia AB
Tel: 00 358 400 419063
E-mail: info@vandergraaf.fi
www.vandergraaf.fi